



SHEFFIELD CITY COUNCIL Committee Report

Report of: Chief Licensing Officer, Head of Licensing

Date: 3rd October 2017 at 11.30am

Subject: Street Trading
Application for a City Centre Street Trading Consent

Author of Report: Stephen Lonnia

Summary: To consider an application for the grant of a City Centre Street Trading Consent to trade on Fargate.

Background Papers: As attached
Street Trading Policy

Category of Report: OPEN

**REPORT OF CHIEF LICENSING OFFICER, HEAD OF LICENSING,
TO THE LICENSING COMMITTEE**

LOCAL GOVERNMENT (MISCELLANEOUS PROVISIONS) ACT 1982

City Centre Street Trading (Fargate) – No Meat Today Ltd - Vegan Food

Ref: 123/17

1.0 PURPOSE OF REPORT

1.1 To consider an application for the grant of a City Centre Street Trading Consent to trade on Fargate.

2.0 INTRODUCTION

2.1 The Council have power under the provision of the 1982 Act to regulate street trading in the city.

2.2 A Street Trading Consent is required to trade on any street (which includes roads, footways, forecourts, or other areas to which the public have access) within the Sheffield City Boundary.

2.3 The Licensing Committee at it's meeting of 29th January 2002 passed the following resolution:

1. That under the provisions of schedule 4 of the Local Government (Miscellaneous Provisions) Act 1982:
 - (a) all streets (which includes roads, footways, forecourts or other areas to which the public have access) within the Sheffield City boundary, shall be designated consent streets and;
 - (b) such street trading designation shall take effect as from the 1st April 2002; and
 - (c) all previous designations in relation to street trading will be rescinded as a result of the designation set out above.
2. The effect of this resolution is that from 1st April 2002, it will be an offence to engage in street trading in any street or any other place identified in the above resolution without being authorised to do so by consent from the City Council.

2.4 A Local Authority may attach conditions to a Street Trading Consent. The conditions may include conditions to prevent obstruction of the street and danger to persons using the street or nuisance or annoyance.

2.5 A Street Trading Consent may only be granted for a maximum period of twelve months.

2.6 There is no appeal procedure against the refusal or revocation of a consent. An applicant may, however apply for judicial review of the Council's decision.

2.7 A copy of the Council's Street Trading Policy will be forwarded to Members prior to the Meeting, a copy of which will also be available on the day.

3.0 CITY CENTRE STREET TRADING

- 3.1 Working in partnership with the City Centre Management Team and Planning, Licensing presented a report to Committee in August 2011 to encourage more local businesses to trade in the city centre whilst also controlling the type and thereby controlling the quality that is on offer.
- 3.2 This is to encourage more local businesses to trade in the city centre and to offer a more continental style of trading in certain areas of the city centre
- 3.3 There is no constraint on the type of goods that can be sold. However, we would like to encourage more traditional goods that would give a more continental style to the City Centre.
- 3.4 A City Centre Qualitative Criteria for Small Trading Stalls was approved to meet these requirements (attached at Appendix 'A').
- 3.5 The fee for consent has been set at £498.50 per quarter (£1,994 per annum) to trade seven days a week between 7am and 7pm.

4.0 THE APPLICATION

- 4.1 An application has been submitted by 'No Meat Today Ltd' on the 14th August 2017 to sell vegan food on Fargate in the city centre. A copy of the application and supporting documentation is attached at Appendix 'B'.
- 4.2 Members are to note the applicant has specified a preferred site which is currently taken by another street trader. This site is referred to as the 'top of fargate' as listed in the below table, the applicant is however open to be sited elsewhere if unable to obtain preferred site. Specific location of site will need to be agreed in conjunction with the City Centre Management Team and the Planning Department.
- 4.3 A number of pitches have been allocated for city centre street trading at a previous meeting, and majority of them have been taken by other Street Traders as detailed below:

Area	Items sold	Consent Free/Taken
Top of Fargate	Sausages, Chips, salad, drinks	Taken
Bottom of Fargate	Ice-cream	Taken
Fargate (granted outside policy numbers)	Pancakes (previously flowers)	Taken
Howard Street	Hot Drinks and sweets	Taken
Devonshire Green	Tea, Coffee and Cake	Taken
Barkers Pool	Burgers, hotdogs, chips etc	Taken
Tudor Square		Free

- 4.3 Members are to also note that there are currently two further applications pending for Fargate which have been deferred by the Licensing Sub-Committee.

4.4 The application was circulated, in the usual manner, to South Yorkshire Police, South Yorkshire Fire and Rescue, Highways and Planning, and City Centre Management.

4.5 No objections have been received.

5.0 REASONS FOR REFERRAL

5.1 The application has been referred to the Licensing Sub-Committee for two reasons

1. Section 3.1.13 of Sheffield's Street Trading Policy refers that all applications for city centre street trading are to be placed before our Licensing Sub-Committee for determination.
2. The applicant is requesting the grant of a street trading consent on Fargate which will be outside the agreed policy numbers of consents in that area.

5.2 Each application must be determined on its own individual merits and Members should consider all information provided by the applicant both in their written application and in person at the meeting.

5.3 The applicant has been invited to attend the Licensing Sub-Committee meeting. A copy of the invite is attached at Appendix 'C'.

5.4 A copy of the hearing procedure is attached at Appendix 'D'.

6.0 FINANCIAL IMPLICATIONS

6.1 There are no financial implications for the Council arising from this report. Street Trading fees are set and reviewed annually on a full cost recovery basis. The level of fee takes into account the location, duration of consent, the trading hours and articles to be sold as well as the enforcement of the terms and conditions.

7.0 RECOMMENDATIONS

7.1 That Members consider all relevant information provided by the applicant both in their written application and in person at the meeting and against Sheffield's Street Trading Policy.

8.0 OPTIONS OPEN TO THE COMMITTEE

8.1 To grant the application for a Static Street Trading Consent at location applied for.

8.2 To grant the application with amendments (which includes an alternative location).

8.3 To defer the matter for further consideration.

8.4 To refuse the grant of the Static Street Trading Consent

Steve Lonnia
Chief Licensing Officer & Head of Licensing
Business Strategy and Regulation, Place Portfolio
Block C Staniforth Road Depot
Staniforth Road, Sheffield S9 3HD

20th September 2017

APPENDIX 'A'

CITY CENTRE QUALITATIVE CRITERIA

CITY CENTRE STREET TRADING Small Trading Stalls

BACKGROUND

Street activities are an essential ingredient of a vibrant and lively city, and in Sheffield there is a strong demand for legitimate small scale trading pitches. They also offer an opportunity for small businesses to get started with relatively modest outlay.

The widening of footways offers the opportunity to designate more pitches in locations that will add to the attractiveness of the City Centre. In Orchard Square and Meadowhall 'Barrow' style stalls are used extensively, enhancing the colour and vitality of those places.

This scheme is part of the City Council's campaign to make Sheffield City Centre a more attractive and vibrant place. Set out below is the qualitative criteria which forms the basis on which to test applications for the grant of designated small trading stall Street Trading Consent sites within the City Centre.

QUALITATIVE CRITERIA – SMALL TRADING STALLS

GENERAL DESIGN

- There will be no motorised vehicles or stalls etc. permitted as part of this scheme.
- All barrows/handcarts must be capable of being moved on and off site by hand and any vehicles used to bring the barrows/handcarts to the site must be parked, loaded and unloaded off site.
- Good display is an important part of the selling process and top quality presentation encourages purchase and benefits the retailer reputation.
- It is in the best interest of traders to produce a high quality design in their barrows/handcarts. The function of the stall is to identify the trader and add vitality and colour to the immediate area, and reflect the quality, cleanliness and order in their operation. The barrow/stall contributes to the appearance of the street for good or bad, so design matters to everyone who uses the street, as well as the operator.
- Sign writing and scrollwork must be finished to a standard acceptable to the City Council.
- The unit must be visually acceptable to the City Council (this will include the Head of Licensing, City Centre Manager and Planning Service) and be in keeping with the street/area that it is to be located.
- Advertisements on stalls will not be permitted except by permission of the Council in writing and subject to further conditions. The Council shall be the sole judge of what is an acceptable advertisement.
- The Council will reserve the right to not renew any consent where it considers the product(s) offered by the operator are not in keeping with the requirements of the site and the promotion of the City Centre.
- Non functional elements attached to barrows / handcarts, are not acceptable.

- The general design of the barrow/handcart must meet the requirements of the Council for that location.
- Flame retardant 'skirts' are to be used if necessary, so as to obscure the frame, gas bottle etc. They should be designed to 'unify' the barrow/handcart.
- All equipment, tools, gas bottles etc. must be self contained within the stall/handcart etc.
- Bright colours and a sense of fun are encouraged.
- Finished in flame retardant paint.
- A colour photograph or scale illustration of the proposed handcart must be submitted to the Licensing Service as part of the application process.
- No barrow/handcart should have a frontage greater than 3.0 metres or a width greater than 2.0metre.
- Roofs should be no more than 2.5m above ground level.
- Pitched and curved roofs are encouraged.
- Canopies should be high quality with a feeling of 'permanence'. These could be manufactured from either stretched canvas, or woven material, opaque or light metal materials. Clear plastic awning and extensions to the canopy will not be acceptable.
- Canopies must be maintained and cleaned to a high standard.
- Food traders must ensure that any stall design satisfies the requirement of food safety legislation. Staff must be adequately trained in good hygiene (Basic Food Hygiene Certificate and regular on going training) and records of training must be made available on request.
- Best practise of food hygiene must be adopted by the operator. This covers:
 - Personal hygiene
 - Hand washing
 - Ill health
 - Prevention of contamination
 - Temperature control
 - Temperature monitoring
 - Cleaning
 - Storage and stock rotation
 - Procedures in the event of freezer breakdown
 - Site cleanliness
 - Waste disposal
 - Pest control
 - Quality control
 - First aid facilities

Food traders must have a minimum food hygiene rating score of 3.

APPENDIX 'B'

APPLICATION AND SUPPORTING DOCUMENTS

Dear Committee members,

In the last few months, I have been working with Business Sheffield team on a business plan for opening a Gluten-free vegan burgers and sausages tricycle in Sheffield City Centre. My goal is to provide a high quality vegan healthy food at an affordable price, made from the best quality ingredients.

Vegan food is a massive worldwide trend, and although there are two great restaurants that provides vegan friendly food (Humpit, Blue Moon Cafe) in the city centre, there is still a high demand by customers to have fast and affordable options, especially when it comes to Gluten-free food.

I have 15 years of experience of working with some of the best restaurants in Manhattan, Sydney and Tel Aviv, and have 9 years of customer service experience, including working with Samsung previously at Curry's PC world, and recently at John Lewis' Sheffield branch.

My goals are:

- Providing British-based premium vegan burgers and sausages, at an affordable price.
- Gaining level 5 food hygiene rating, with the help and support of NCASS (National Catering Association). Vegan food considered to be very low risk food, and I will work only with suppliers and manufacturers that have level 5 food hygiene rating. I recently received NCASS food hygiene level 3 certificate, to make sure that I'll be able to provide the best quality food.
- Giving an exceptional great service to all of the customers. Due to my customer service skills, I received an award as Samsung's best service provider in the country for 2015. customer service is a real passion to me. I would like to create fun and friendly experience to the wonderful people of Sheffield.
- To provide the safest work environment, a national Living Wage (will be calculate by London's rate, currently £9.15 per hour), provide free NCASS Level 2 training to all assistants, and be a part of the fair trade movement.

After weeks of research, I found out that the best design for both practicality and to give a sense of fun, is the use of an Eco-friendly tricycle.

The tricycle will have a traditional design that can be changed and modified by the management team requests and suggestions, and will provide a safe working environment, according to the health and safety regulations.

The tricycle made with the highest industry standards, using the best 304 food grade stainless steel with high quality aluminium plate surround. A sink with a 12V pump and two 5 litres containers for fresh water and waste.

The top quality LPG griddle is recommended by the National Catering Association, and is certified to the highest standards, gas bottle will be placed inside the end box.

The roof holds an eco-friendly solar panel, which will provide green energy to the LED light strip.

The tricycle will come with a full body wind and rain protection, made of the best materials, to provide a safe working environment.

Both Business Sheffield and myself like to ask for your support in this application.

Thank you for your time and help,

Kind regards,

Adi Sela

Local Government (Miscellaneous Provisions) Act 1982

Rec - 72385
E100 - coal

Application for a (City Centre – small unit) Street Trading Consent

Notes to Applicant:

All questions must be answered unless otherwise stated.
If relevant questions are not answered, the application will be deemed incomplete and returned to the Applicant.

*I / *WE HEREBY APPLY to the Sheffield City Council for the grant of a (city centre – small unit) street trading consent.

A. THE APPLICANT(S)

LICENSING
1 AUG 2017
SERVICES

		1 st Applicant (Mr/Mrs/Miss/other)	2 nd Applicant (Mr/Mrs/Miss/other)
Q1	Full name(s) of the applicant		
Q2	Applicant(s) permanent private address		
Q3	Date of birth		
Q4	Nationality and place of birth		
Q5	National Insurance No.		
Q6	Do you have the legal right to work and live in the UK?	YES / NO Details:	YES / NO Details:
Q7	Have you ever been refused a street trading consent in this or any other area?	YES / NO Details:	YES / NO Details:
Q8	Telephone No		
Q9	Email address		

B. COMPANY DETAILS (if applying as a Corporate body)

Q10	Name	No Meat Today Limited
Q11	Registered address	[REDACTED] [REDACTED] [REDACTED]
Q12	Registered number	10874298
Q13	Telephone number	[REDACTED]
Q14	Email address	[REDACTED]
Q15	Please provide details of all Directors (names, addresses, dates of birth and details of any convictions). A separate sheet may be used.	Adi Sela, [REDACTED] [REDACTED] [REDACTED] No convictions.

C. TRADING DETAILS

Q16	Trading Name (if applicable)	No Meat Today
Q17	Trading address (if different from above) Post Code	
Q18	Site to be occupied	Fargate, see plan for preferred site. Happy to be sited anywhere.
Q19	Items to be sold (i.e. type of food, jewellery, paintings, etc)	Vegan burgers, vegan sausages, snacks
Q20	Please specify preferred days of trade:	7 days
Q21	Please specify preferred hours of trade:	07:00 – 19:00

D. THE UNIT

Q19	Type: eg barrow / cart, etc.	Tricycle
Q20	Size of unit	Height: 2500mm Width: 1100mm when close, 2000mm when open Length: 2400mm

E. CONVICTIONS / CAUTIONS

Q21	Have any of the applicants ever been convicted of a criminal offence, whether in the United Kingdom or elsewhere? If the answer is Yes please give full details below:	Applicant 1 Yes [] No [No]	
		Applicant 2 Yes [] No []	
Details of previous convictions and/or cautions			
	Date of Conviction	Court of Conviction	Nature of Offence
	Applicant 1		
	Applicant 2		

F. CHECK LIST

The following documents must be attached with this application:

(tick)

Non refundable fee of £100	
Your current passport	/
Your current drivers licence	/
One other proof of identity, showing your name and current address (recent utility bill, bank statement etc)	/
Right to work documentation (if applicable)	N/A
Two (recent and identical) passport size photographs signed and dated on the reverse as a true likeness.	✓
Photographs of the vehicle / unit, front back and rear.	✓
Details of any food hygiene qualifications (unless trading in non food items)	✓
If trading in food, confirmation that the business has a food hygiene score rating of 3 or more.	-
Confirmation your vehicle meets the quality criteria	-
Any further information you may wish to submit in support of your application	✓

The following documents must be forwarded to us before the grant of your consent:

(tick if enclosed with this application)

The remaining quarterly fee or full annual fee.	
Certificate of insurance in respect of the vehicle / unit	
Public liability insurance (minimum of £2,000,000)	
Written confirmation that the vehicle meets the Council's food safety standards	
Waste management contract	
Declare that you have registered as a food business	

G. DECLARATION

WARNING

Paragraph 10(3) of Schedule 4 to the Local Government (Miscellaneous Provisions) Act 1982 gives the following warning:-

“Any person who, in connection with an applicationfor a street trading consent, makes a false statement which he knows to be false, in any material respect, or which he does not believe to be true, shall be guilty of an offence.”

I / We,

- declare that all the information I have given in this application is complete and correct;
- declare that I am over 17 years of age (in cases of individual applicants)
- declare I understand and will comply with the Sheffield City Council Street Trading Consent Conditions;
- undertake to pay Sheffield City Council the relevant consent fee in advance whether demanded or not;
- understand that consents are not transferable;
- understand that the Local Authority reserve the right to make further enquiries with South Yorkshire Police as a result of this application as they may consider desirable; and
- understand that giving false information is an offence and may result in prosecution and / or a street trading consent being refused or revoked:

	<p>Applicant 1</p> <p>Signature: </p> <p>Print name: ADI SELA</p> <p>Date: 14.8.17</p> <p>Capacity: Director</p>
	<p>Applicant 2</p> <p>Signature:</p> <p>Print name:</p> <p>Date:</p> <p>Capacity:</p>

Please read these notes before completing the application form.

- If there is insufficient room on this form to fully answer the questions; or if you wish to make any further statement in support of your application, please do so on a separate sheet of paper attached to this form.
- None of the information which you supply on (or with) this form will be treated as confidential except where it relates to convictions.
- The Council is under no obligation whatsoever to grant a consent to any person; you will be notified of the result of this application, as soon as possible.

Please return the fully completed form and all attachments to:

**Licensing Service,
Block C, Staniforth Road Depot
Staniforth Road
Sheffield
S9 3HD**

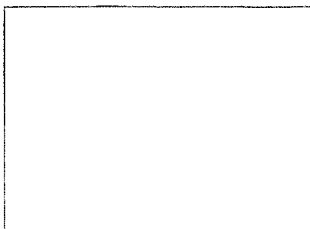
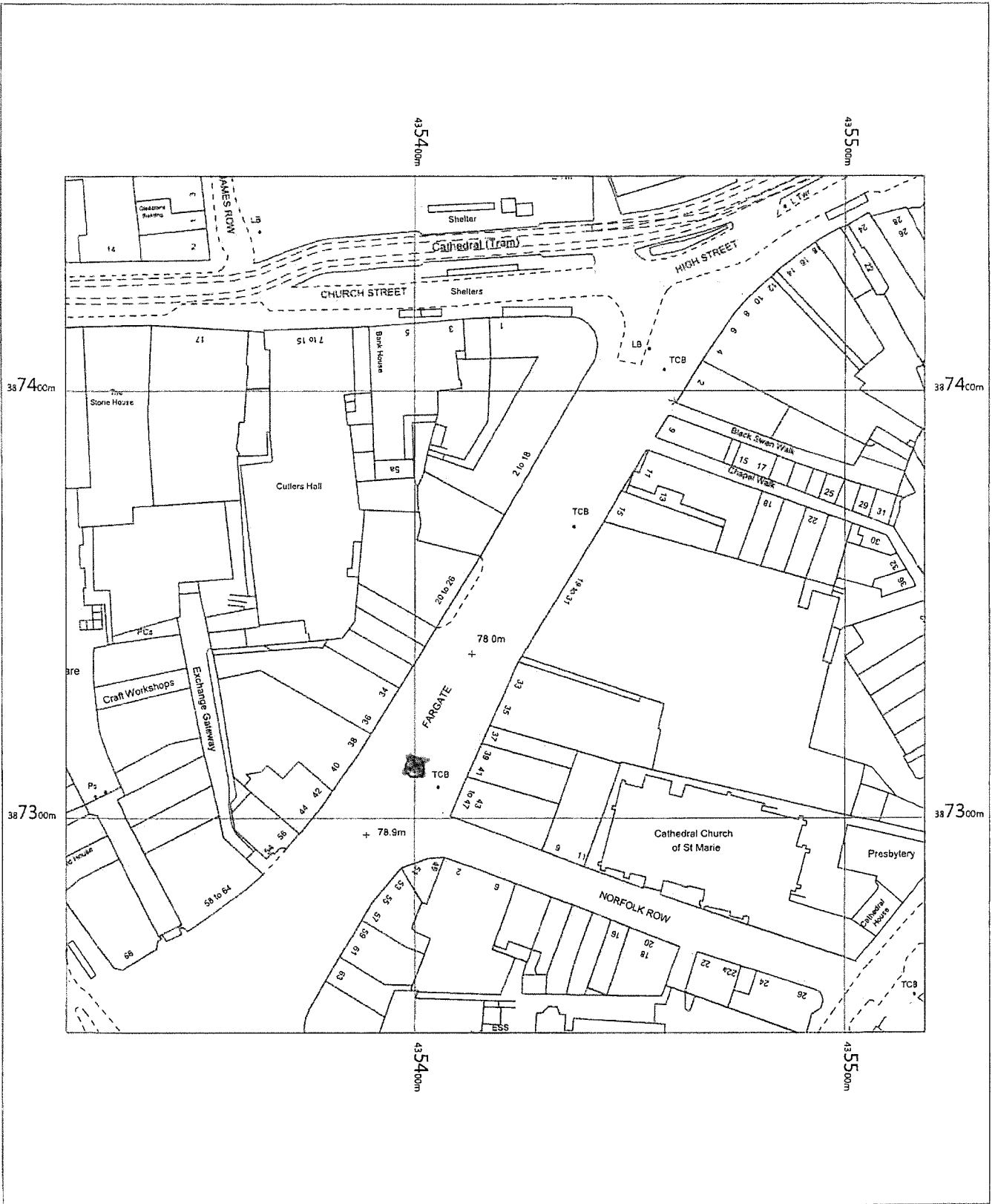

OS MasterMap 1250/2500/10000 scale
 Thursday, August 3, 2017, ID: BW1-00645058
www.blackwellmapping.co.uk

1:1250 scale print at A4, Centre: 435419 E, 387350 N

©Crown Copyright Ordnance Survey Licence No. 100071041



BLACKWELL'S
www.blackwellmapping.co.uk

TEL: 0114 268 7658
maps.sheffield@blackwell.co.uk

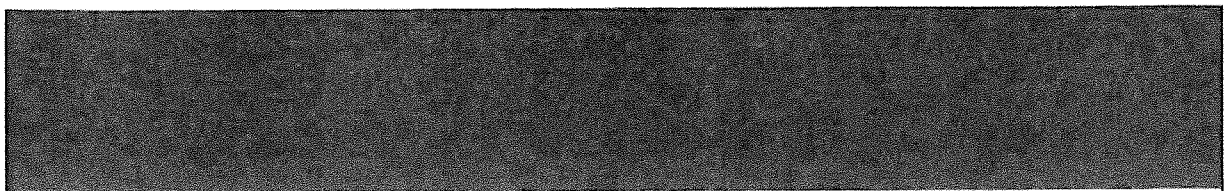

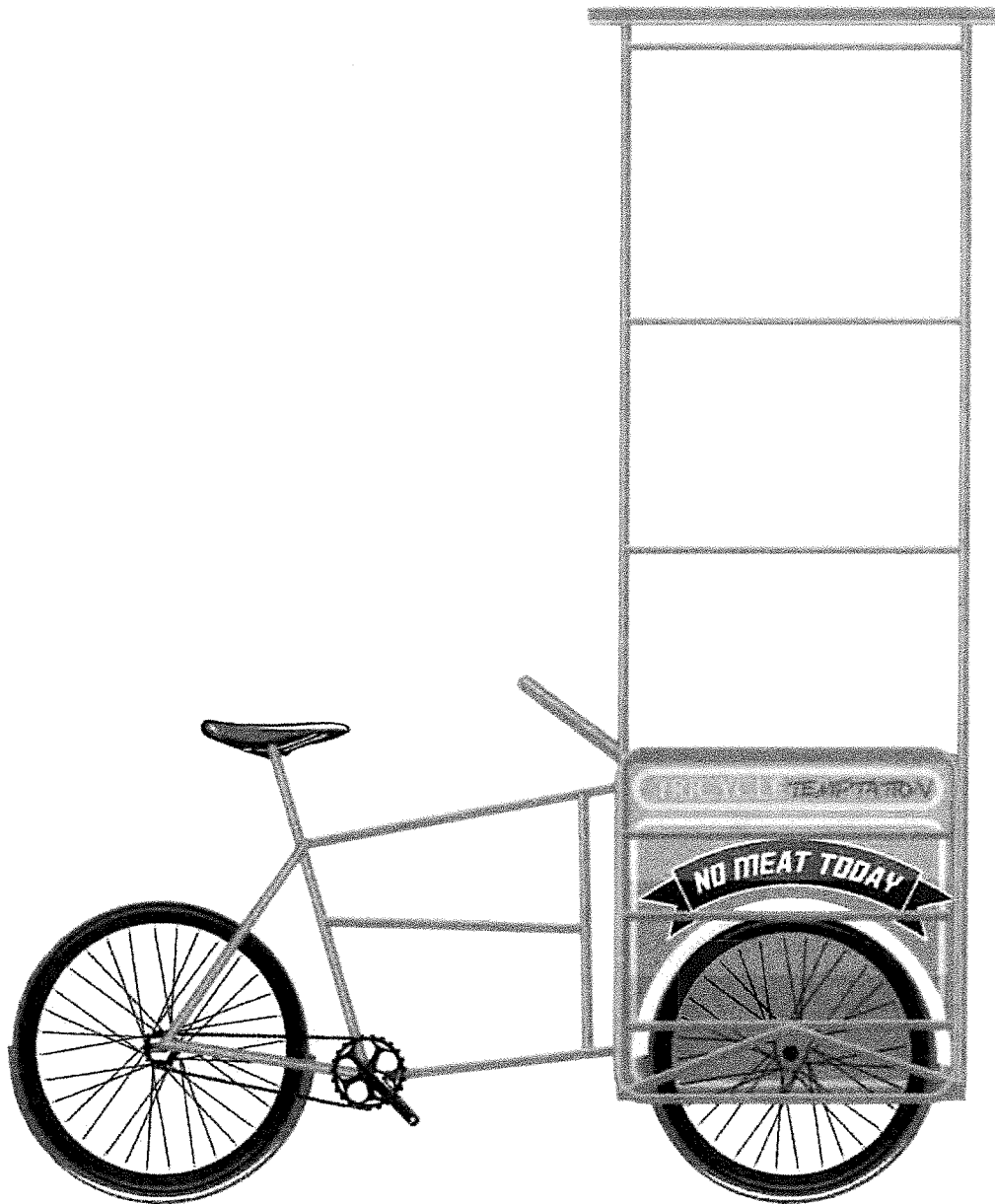

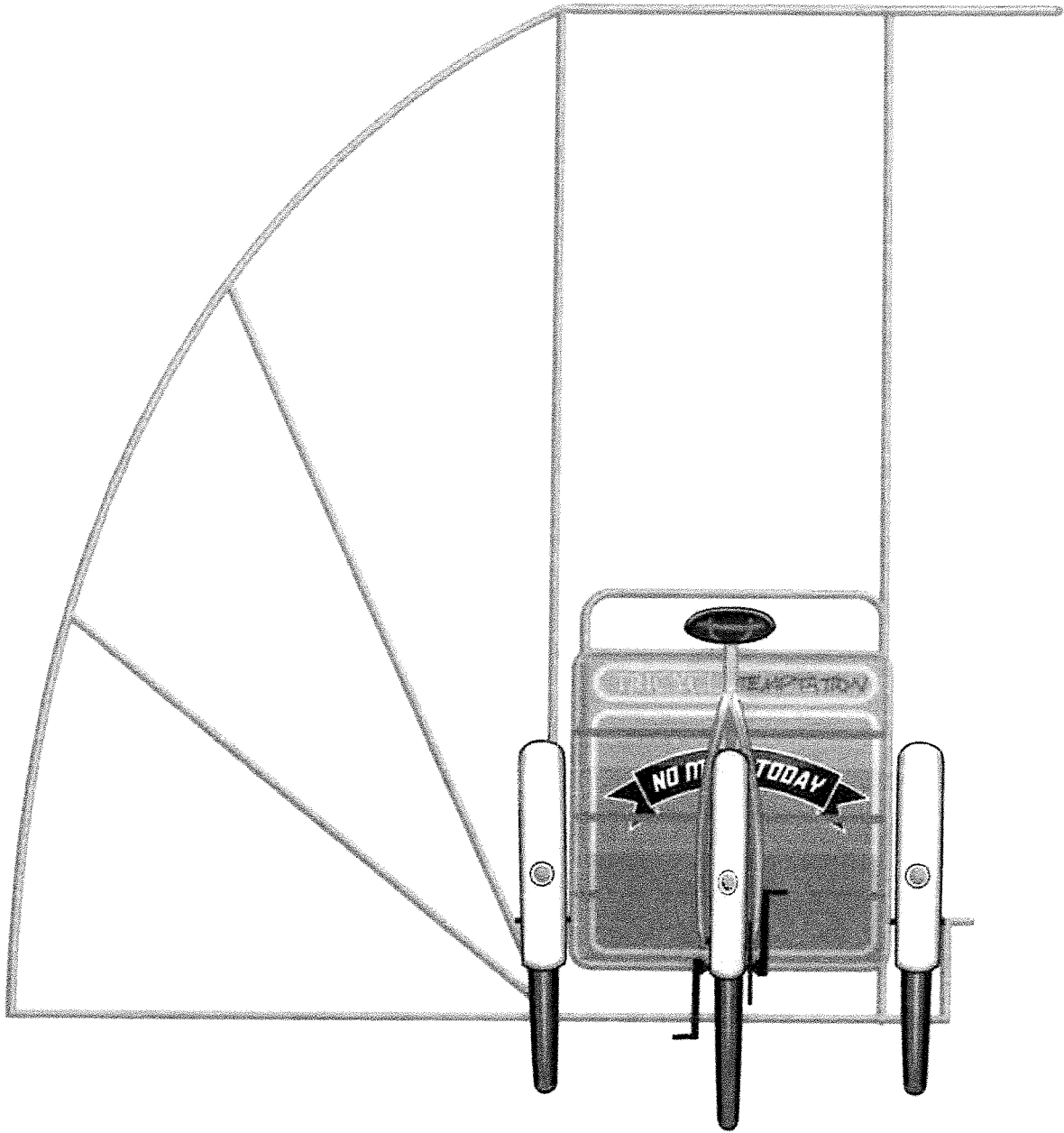

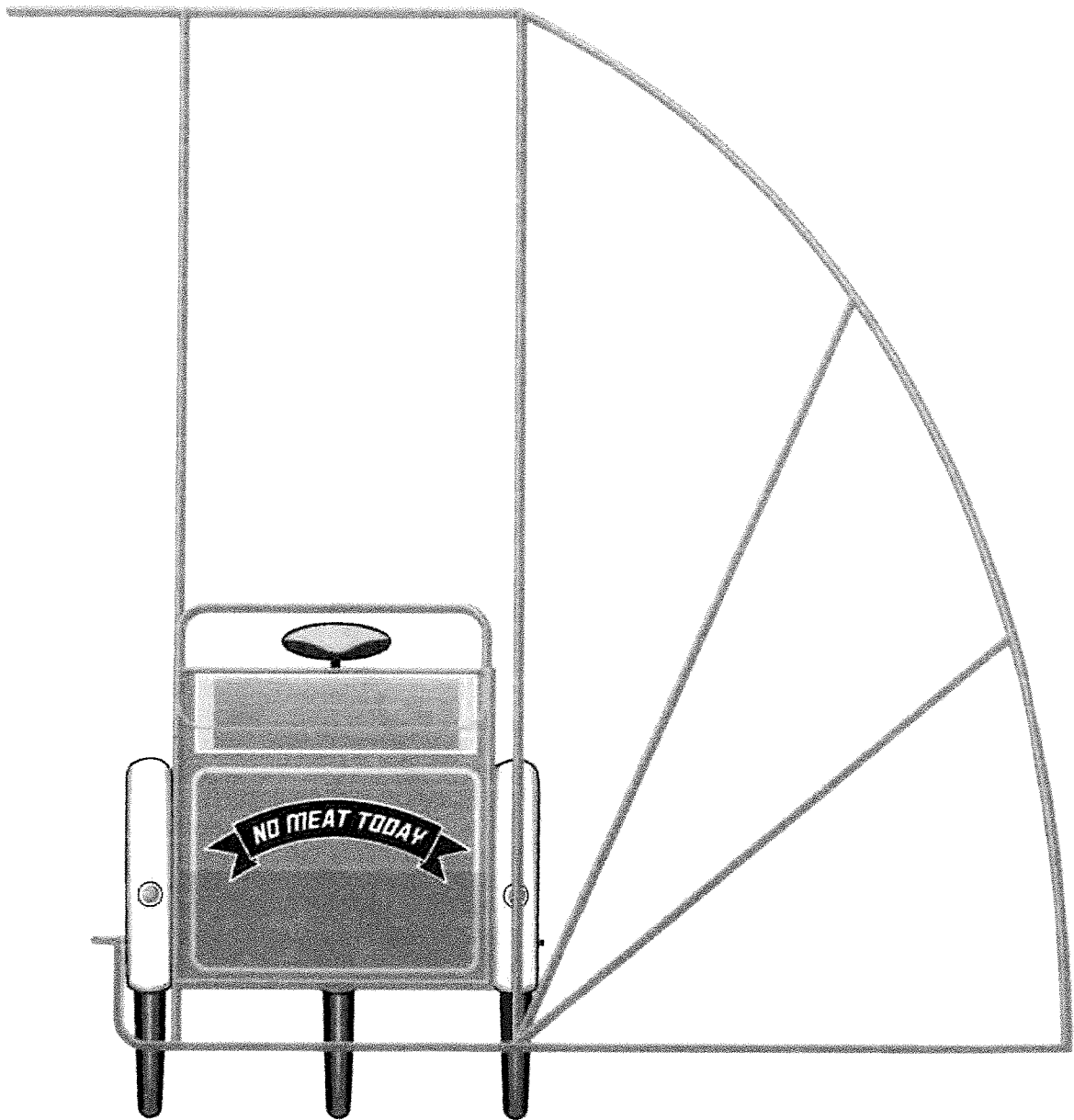

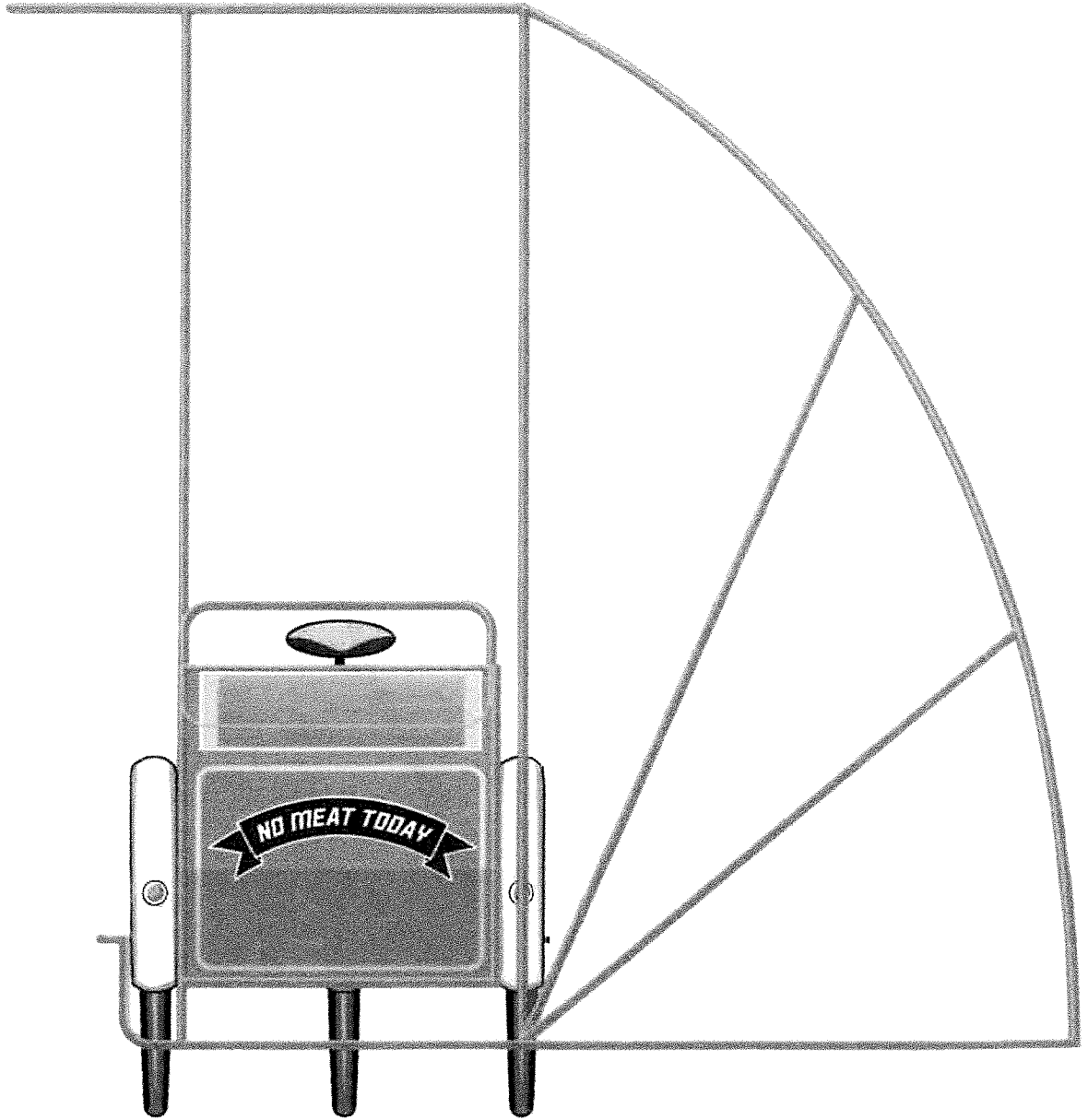

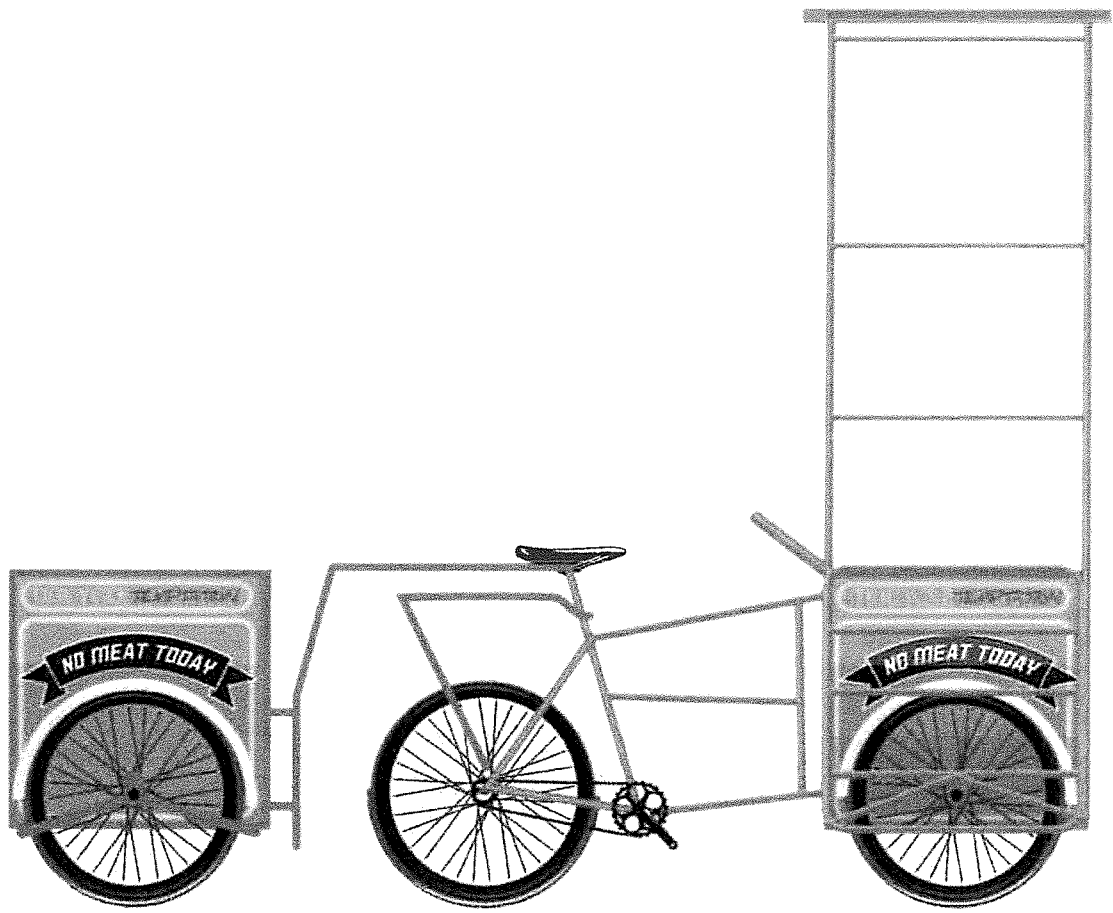

EXAMPLE OF Wind Protection
ON BIKE

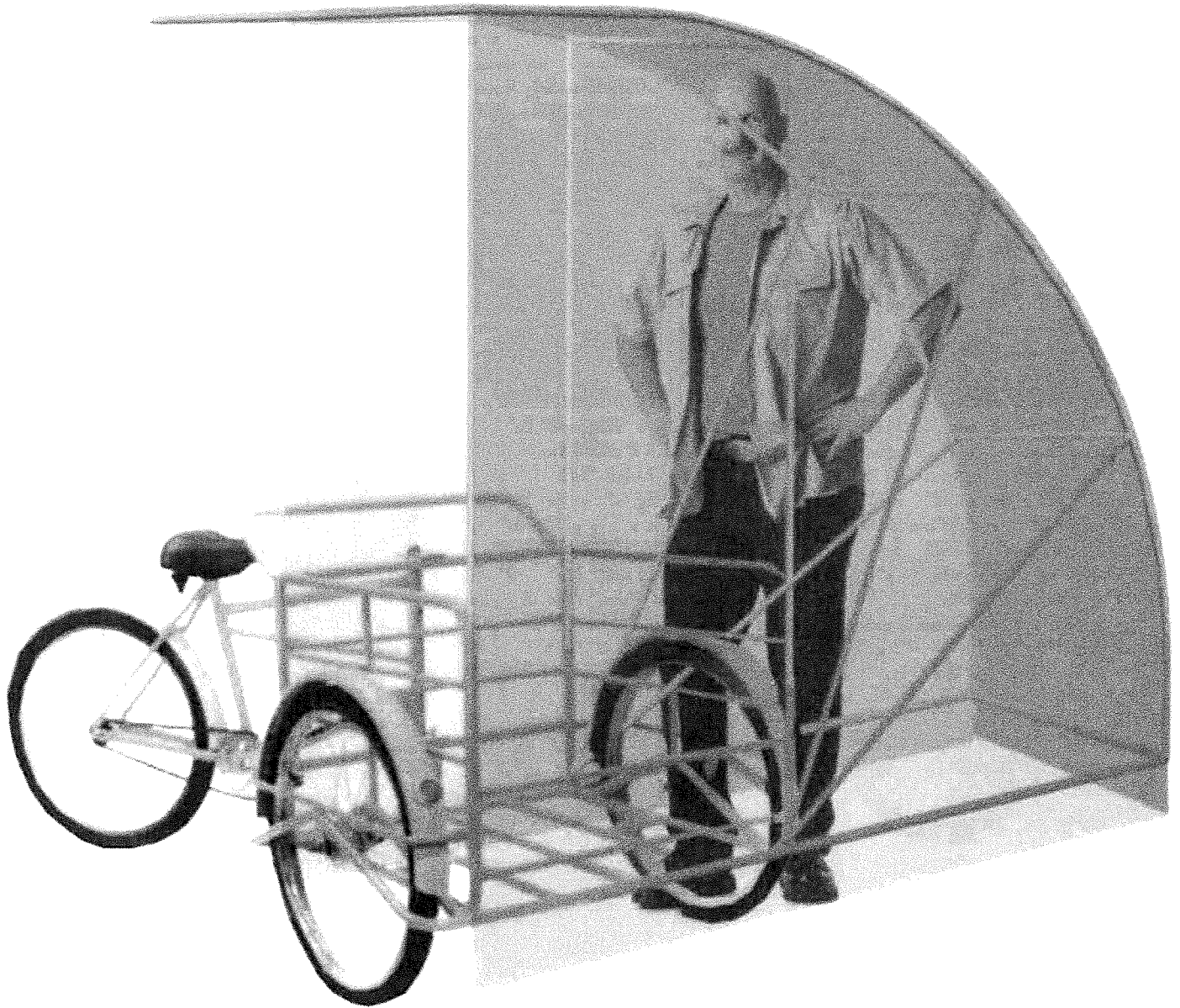

EXAMPLE OF INTERNAL SETTINGS

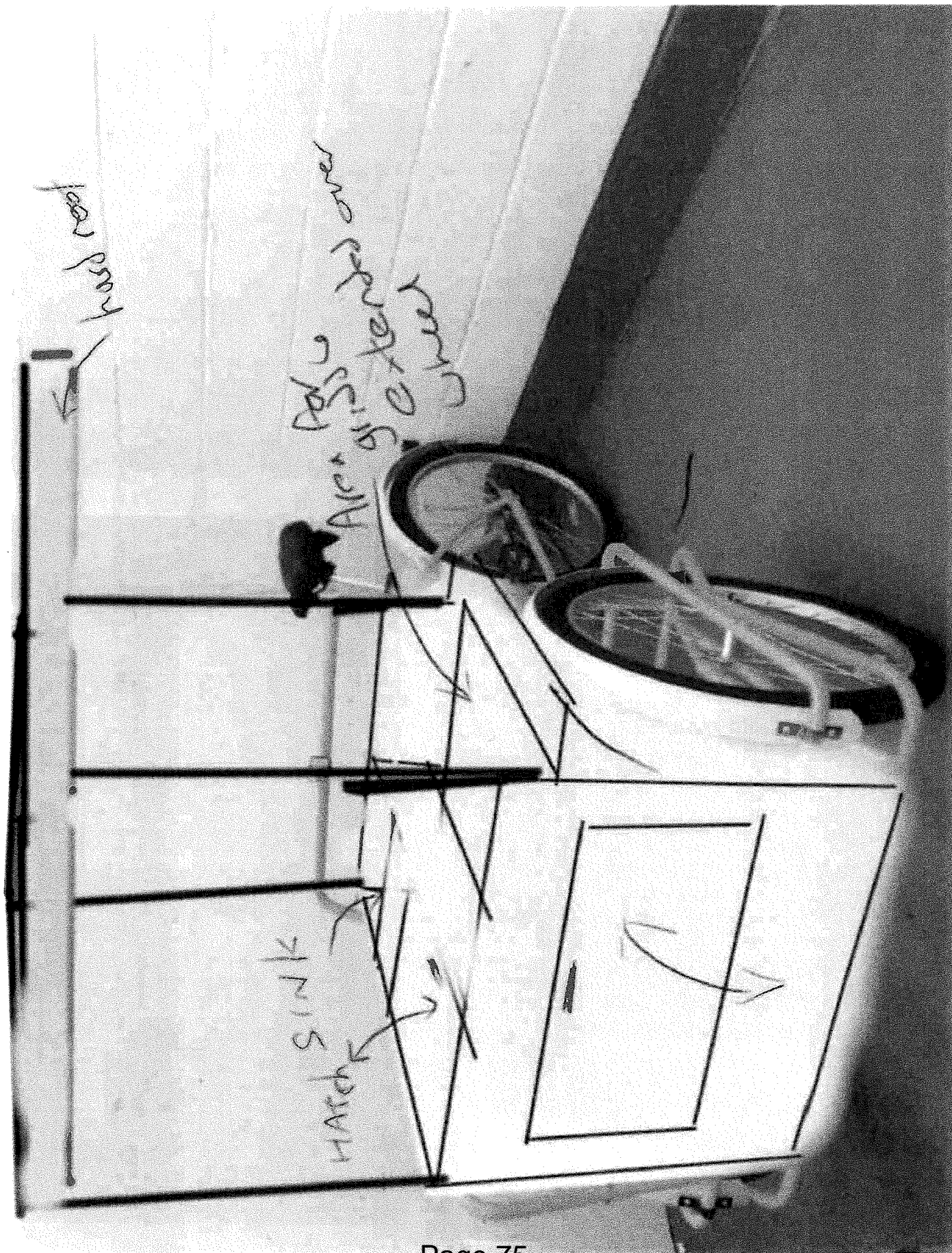

EXAMPLE OF TRICE.



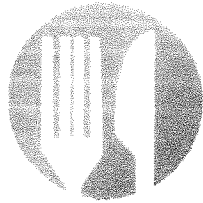

NCASS
NATIONWIDE
CATERERS
ASSOCIATION

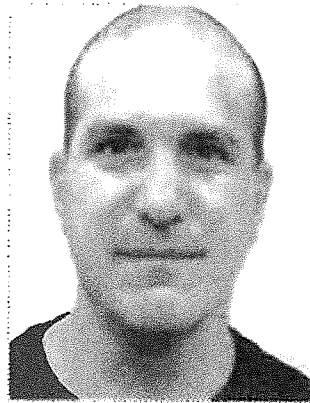

City & Guilds | **Accredited**
Programme

NCASS FOOD HYGIENE LEVEL 3

Awarded to:
Adi Sela

This is to certify that the above named has completed an online course in the following subjects:

Supervisory Management, Food Safety, Microbiology, Hazards, Pest Control, Temperature Control, Cleaning, Contamination Control, Applying & Monitoring Good Food Safety Measures, Quality Control, Contributing to the Food Safety Training of Others, Legislation.

Date Taken: 21/Jul/2017

Valid Until: 21/Jul/2020

R Fox (Director)
 On behalf of the Association

Cherwell
 DISTRICT COUNCIL
 NORTH OXFORDSHIRE

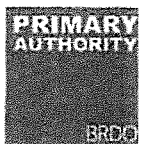

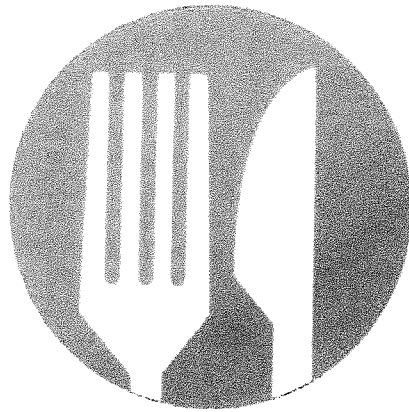

NCASS
NATIONWIDE
CATERERS
ASSOCIATION

This is to Certify that

No Meat Today

Is a member of

**The Nationwide Caterers
Association**

Membership No: 18528

Valid Until: 18/Jul/2018

Tel: 0121 603 2524, ~~and~~ Web: www.ncass.org.uk

Rhodes Emma (CEX)

From: Adi Sela [REDACTED]
Sent: 12 September 2017 11:55
To: Rhodes Emma (CEX)
Subject: Fwd: Vegan food tricycle application

Begin forwarded message:

From: "Murphy Robert (GN CLLR)" <Robert.Murphy@sheffield.gov.uk>
Date: 12 September 2017 at 11:40:23 BST
To: 'Adi Sela' [REDACTED]
Subject: RE: Vegan food tricycle application

Hi Adi,

Sorry for the long delay in replying. I have no objections, good luck.

Kind regards, Rob

From: Adi Sela [REDACTED]
Sent: 11 August 2017 13:14
To: Murphy Robert (GN CLLR)
Subject: Vegan food tricycle application

Dear councilor Robert Murphy,

I would like to ask for your support with this application

In the last few months, I have been working with Business Sheffield team on a business plan for opening a Gluten-free vegan burgers and sausages tricycle in Sheffield City Centre. My goal is to provide a high quality vegan healthy food at an affordable price, made from the best quality ingredients.

Vegan food is a massive worldwide trend, and although there are two great restaurants that provides vegan friendly food (Humpit, Blue Moon Cafe) in the city centre, there is still a high demand by customers to have fast and affordable options, especially when it comes to Gluten-free food.

I have 15 years of experience of working with some of the best restaurants in Manhattan, Sydney and Tel Aviv, and have 9 years of customer service experience, including working with Samsung previously at Curry's PC world, and recently at John Lewis' Sheffield branch.

My goals are:

- Providing British-based premium vegan burgers and sausages, at an affordable price.

- Gaining level 5 food hygiene rating, with the help and support of NCASS (National Catering Association). Vegan food considered to be very low risk food, and I will work only with suppliers and manufacturers that have level 5 food hygiene rating. I recently received NCASS food hygiene level 3 certificate, to make sure that I'll be able to provide the best quality food.
- Giving an exceptional great service to all of the customers. Due to my customer service skills, I received an award as Samsung's best service provider in the country for 2015. customer service is a real passion to me. I would like to create fun and friendly experience to the wonderful people of Sheffield.
- To provide the safest work environment, a national Living Wage (will be calculate by London's rate, currently £9.15 per hour), provide free NCASS Level 2 training to all assistants, and be a part of the fair trade movement.

After weeks of research, I found out that the best design for both practicality and to give a sense of fun, is the use of an Eco-friendly tricycle. The tricycle will have a traditional design that can be changed and modified by the management team requests and suggestions, and will provide a safe working environment, according to the health and safety regulations.

The tricycle made with the highest industry standards, using the best 304 food grade stainless steel with high quality aluminium plate surround. A sink with a 12V pump and two 5 litres containers for fresh water and waste. The top quality LPG griddle is recommended by the National Catering Association, and is certified to the highest standards, gas bottle will be placed inside the end box.

The roof holds an eco-friendly solar panel, which will provide green energy to the LED light strip.

The tricycle will come with a full body wind and rain protection, made of the best materials, to provide a safe working environment.

Photo example attached.

Both Business Sheffield and myself would like to ask for your support with this application.

Thank you for your time and help,

Kind regards,

Adi Sela

Johnson Douglas (GN CLLR)
RE: Vegan food tricycle application
12 Aug 2017, 15:34:28
Adi Sela [REDACTED]

Thanks Adi - no, it sounds like a positive thing to me so good luck with it.

Regards,
Douglas

Cllr Douglas Johnson,
City Ward, Sheffield (Green Party)
[07500 766 189](tel:07500766189)

From: Adi Sela [REDACTED]
Sent: 11 August 2017 19:26
To: Johnson Douglas (GN CLLR)
Subject: Re: Vegan food tricycle application

Dear Douglas Johnson,

Thank you for your quick reply, I appreciate that.
At this point the biggest support that I can hope for, is simply to have no objections from the respectable councilors, if and when the licensing committee will ask for comments.

Also, I will love to discuss charity events in the future.

Thank you again,
Kind regards,
Adi

On 11 Aug 2017, at 19:17, Johnson Douglas (GN CLLR) <Douglas.Johnson@sheffield.gov.uk> wrote

Hi Adi,

This sounds very positive and you have obviously put a lot of thought into this enterprise. What sort of support did you have in mind though?

Regards,
Douglas

Cllr Douglas Johnson,
City Ward, Sheffield (Green Party)
[07500 766 189](tel:07500766189)

From: Adi Sela [REDACTED]
Sent: 11 August 2017 13:11
To: Johnson Douglas (GN CLLR)

Subject: Vegan food tricycle application

Dear councilor Douglas Johnson,

I would like to ask for your support with this application

In the last few months, I have been working with Business Sheffield team on a business plan for opening a Gluten-free vegan burgers and sausages tricycle in Sheffield City Centre. My goal is to provide a high quality vegan healthy food at an affordable price, made from the best quality ingredients.

Vegan food is a massive worldwide trend, and although there are two great restaurants that provides vegan friendly food (Humpit, Blue Moon Cafe) in the city centre, there is still a high demand by customers to have fast and affordable options, especially when it comes to Gluten-free food.

I have 15 years of experience of working with some of the best restaurants in Manhattan, Sydney and Tel Aviv, and have 9 years of customer service experience, including working with Samsung previously at Curry's PC world, and recently at John Lewis' Sheffield branch.

My goals are:

- Providing British-based premium vegan burgers and sausages, at an affordable price.
- Gaining level 5 food hygiene rating, with the help and support of NCASS (National Catering Association). Vegan food considered to be very low risk food, and I will work only with suppliers and manufacturers that have level 5 food hygiene rating. I recently received NCASS food hygiene level 3 certificate, to make sure that I'll be able to provide the best quality food.
- Giving an exceptional great service to all of the customers. Due to my customer service skills, I received an award as Samsung's best service provider in the country for 2015. customer service is a real passion to me. I would like to create fun and friendly experience to the wonderful people of Sheffield.

- To provide the safest work environment, a national Living Wage (will be calculate by London's rate, currently £9.15 per hour), provide free NCASS Level 2 training to all assistants, and be a part of the fair trade movement.

After weeks of research, I found out that the best design for both practicality and to give a sense of fun, is the use of an Eco-friendly tricycle. The tricycle will have a traditional design that can be changed and modified by the management team requests and suggestions, and will provide a safe working environment, according to the health and safety regulations.

The tricycle made with the highest industry standards, using the best 304 food grade stainless steel with high quality aluminium plate surround. A sink with a 12V pump and two 5 litres containers for fresh water and waste. The top quality LPG griddle is recommended by the National Catering Association, and is certified to the highest standards, gas bottle will be placed inside the end box.

The roof holds an eco-friendly solar panel, which will provide green energy to the LED light strip.

The tricycle will come with a full body wind and rain protection, made of the best materials, to provide a safe working environment.

Photo example attached.

Both Business Sheffield and myself would like to ask for your support with this application.

Thank you for your time and help,

Kind regards,

Cooper Steve (DEL)
RE: Veggie burgers pitch advice
11 Jul 2017, 13:39:51
Adi Sela [REDACTED]

Hello Adi,

Thanks for your email.

I have had a look at the pictures of the bike you are considering trading from and the proposed product and think it would make a great addition to the City Centre street food scene. If you decide to proceed with an application for one of the sites we would have no objections based on the information provided below.

Regards
Steve

Steve Cooper
City Centre Resources Manager
Business Management Team
Sheffield City Council
City Centre Management Unit
177 The Arcade
S1 2EG
0114 2736832/0797 0736732

From: Adi Sela [REDACTED]
Sent: 11 July 2017 11:43
To: Cooper Steve (DEL)
Subject: Veggie burgers pitch advice

Dear Sir/Madam,

I would like to ask for your expert advice about opening a stand in the city centre.

In the last few weeks, I have been working with the Business Sheffield team on a business plan for opening a Veggie burgers and sausages pitch in Sheffield City Center. My goal is to provide a high quality vegetarian and vegan healthy food at an affordable price, made from the best quality ingredients

I have 15 years of experience of working with some of the best restaurants in Manhattan, Sydney and Tel Aviv, and have 9 years of customer service experience, including working with Samsung previously at Curry's PC world, and recently at John Lewis' Sheffield branch.

Providing British premium vegetarian/vegan sausages, at an affordable price.

Gaining level 5 food hygiene rating.

Giving an exceptional great service to all of the customers.

Creating fun and friendly experience to the wonderful people of Sheffield.

To provide the safest work environment.

After weeks of research, I found out that the best design for both practicality and to give a sense of fun, is to use an Eco-friendly tricycle cart. The tricycle will have a traditional design that can be changed and modified by the management team requests and suggestions, and will provide a safe working environment, according to the health and safety regulations. All the products will be provided by high quality British based companies. Waste packaging will be taken to a recycle center.

Both Business Sheffield and myself like to ask for your support in this application, and will be thankful for your input.

Thank you for your time and help,

Best regards,

Adi Sela

planningdc.cityeast@sheffield.gov.uk
RE: Vegan food tricycle application
11 Aug 2017, 16:38:18

[REDACTED]
licensing@cityeast.sheffield.gov.uk

Dear Adi,

Thanks you for your e-mail.

Whilst there are no in principle objections to your proposal from a planning perspective I can advise that the Council's Licensing Service deal with all applications for street trading in the city centre.

I have replied my response to them so that they can explain the application process to you.

Regards,

Lucy Bond
Acting Business Manager & Area Team Manager
(City Centre & East Area)
Development Management
Planning Service
City Growth
Sheffield City Council

We offer an integrated planning and building control service

Website: www.sheffield.gov.uk/cityeast or www.sheffield.gov.uk/buildingcontrol

Location: 4th Floor Howden House, 1 Union Street, Sheffield S1 2SH

Apply for planning permission online at: www.sheffield.gov.uk/planning

Apply for building regulation permission online to: www.sheffield.gov.uk/buildingcontrol



- Stack Sites into the Excellence in Planning to Deliver Housing category
- City to Green into the Excellence in Planning to Create Economically Successful Places category

From: licensing@cityeast.sheffield.gov.uk
Sent: 11 August 2017 13:32
To: planningdc.cityeast@sheffield.gov.uk
Subject: FW: Vegan food tricycle application

From: Adi Sel [REDACTED]
Sent: 11 August 2017 13:21
To: planningdc.cityeast@sheffield.gov.uk
Subject: Vegan food tricycle application

Dear Sir/Madam,

I would like to ask for your support with this application.

In the last few months, I have been working with Business Sheffield team on a business plan for opening a Gluten-free vegan burgers and sausages tricycle in Sheffield City Centre. My goal is to provide a high quality vegan healthy food at an affordable price, made from the best quality ingredients.

Vegan food is a massive worldwide trend, and although there are two great restaurants that provides vegan friendly food (Humpit, Blue Moon Cafe) in the city centre, there is still a high demand by customers to have fast and affordable options, especially when it comes to Gluten-free food.

I have 15 years of experience of working with some of the best restaurants in Manhattan, Sydney and Tel Aviv, and have 9 years of customer service experience, including working with Samsung previously at Curry's PC world, and recently at John Lewis' Sheffield branch.

My goals are:

APPENDIX 'C'

APPLICANT MEETING INVITE

SHEFFIELD CITY COUNCIL

LOCAL GOVERNMENT MISCELLANEOUS PROVISIONS ACT 1982

Street Trading – City Centre Street Trading Consent – Fargate

IMPORTANT: NOTIFICATION OF A COMMITTEE MEETING

To: Mr Adi Sela c/o No Meat Today Ltd



Email: eddie.sela@me.com

LEGISLATION: Local Government (Miscellaneous Provisions) Act 1982

LICENCE TYPE: City Centre Street Trading Consent – Fargate

I refer to the above and the application for the grant of a city centre street trading consent.

This matter has been referred to the Licensing Committee of Sheffield City Council for determination. Full details will be provided in the report to the Committee which will be sent to you in due course. The Licensing Committee has the authority to decide what action to take in relation to each application.

The Committee has indicated that it expects applicants, interested parties and any objectors to attend the meeting.

The meeting in respect of the application will take place on **Tuesday 3rd October 2017** in a Committee Room of the Town Hall, Sheffield, S1 2HH (Pinstone Street entrance) and you are invited to attend at **11:30 am**.

PLEASE NOTE:

I would be grateful if you could confirm that you will be attending the meeting by telephoning the Licensing Office on 0114 2734264.

Handwritten signature of Steve Lonnia in black ink.

.....
Steve Lonnia
Chief Licensing Officer
Head of Licensing

Date: 20th September 2017

IMPORTANT: A DECISION IS LIKELY TO BE MADE ON THIS ISSUE WHETHER YOU MAKE REPRESENTATION OR NOT.

Licensing Service, Business Strategy and Regulation, Block C Staniforth Road Depot,
Staniforth Road, Sheffield, S9 3HD Telephone 0114 2734264

**The Licensing Service Reception is open from 10.00am to 4.00pm, Monday to Friday.
Telephone calls can be taken from 09:00am to 5:00pm.**

APPENDIX 'D'

HEARING PROCEDURE

**STREET TRADING CONSENT APPLICATION
SUB-COMMITTEE HEARING PROCEDURE**

This procedure has been drawn up to assist those parties attending Street Trading Consent Committee hearings.

1. The Chair of the Licensing Committee will introduce the Committee and ask officers to introduce themselves.
2. The Chair will ask the applicants and interested parties to formally introduce themselves.
3. The Solicitor to the Committee will outline the procedure to be followed at the hearing.
4. Hearing Procedure:-
 - (a) The Licensing Officer will introduce the report.
 - (b) Questions concerning the report can be asked both by Members and the applicant.
 - (c) The applicant/consent holder (or his/her nominated representative) will then be asked to:-
 - (i) detail the application;
 - (ii) provide clarification on the application and respond to the representations made.
 - (d) The Chair of the Licensing Committee will invite Members of the Sub-Committee and all other parties present to put any relevant questions to the applicant and/or his/her representative.
 - (e) Consultees / interested parties will be invited to present their representations or elect a spokesperson (which may be a Councillor) to speak on their behalf. New representations must not be raised.
 - (f) The Chair of the Licensing Committee will invite Members of the Sub-Committee and all other parties present to put any relevant questions to the consultees / interested parties.
 - (g) The consultees / interested parties will be invited to sum up. A maximum of 5 minutes will be allowed.
 - (h) The applicant will be invited to sum up. A maximum of 5 minutes will be allowed.
 - (i) The Licensing Officer will then detail the options.
 - (j) There will then be a private session for Members to take legal advice and consider the application.
 - (k) Once a decision has been reached, all parties will be invited to return. The Sub-Committee's decision and reasons will be announced by the Chair.
 - (l) The Sub-Committee's decision will be confirmed in writing to the applicant and those parties who made representations.

- NB:
- 1) At any time in the Licensing Process Members of the Committee may request legal advice from the Solicitor to the Committee. This advice may be given in open session or in private.
 - 2) The Committee Hearing will be held in public unless and in accordance with the Regulations the Committee determine that the public should be excluded.

There is no right of appeal against the Council's decision to refuse to grant or revoke a Street Trading Consent

